



ARAGON
U M P S

CP SERIES



Submersible Sewage Pump

CP, CPS Submersible Sewage Pump

Design

CP, CPS Submersible Sewage Pump are designed for economical and reliable pumping of sewage water from commercial, communal and industrial sources.

They are suitable for clear and waste water containing solid and fibrous material.

Used in conjunction with the automatic coupling system the below ground level wet installation is a particularly economical solution which also does not damage the environment.

The pump are also suitable for quick portable applications.

Maximum Temperature: +40°C

Materials

Casing — Cast Iron FC20
 Shaft — Stainless Steel SUS316
 Impeller — Cast Iron FC20
 Fasteners — Stainless Steel SUS304

Special materials on request

Mode Code

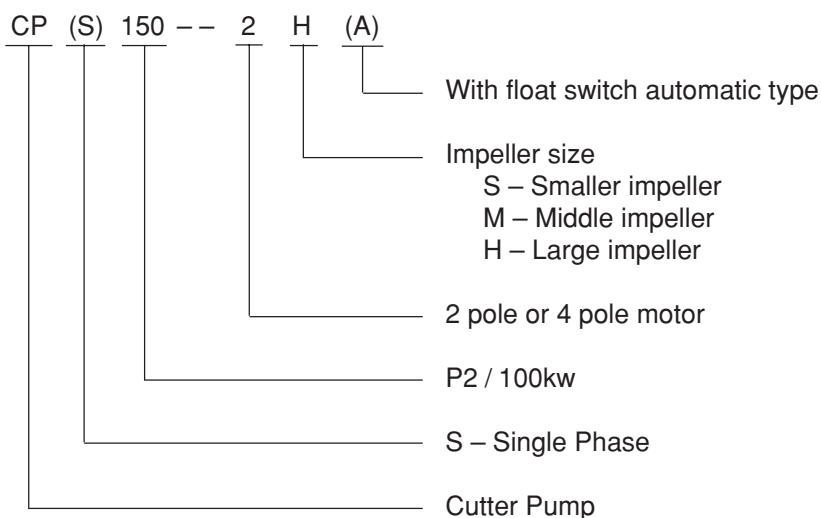

Automatic-Coupling System Installation (wet installation, stationary)

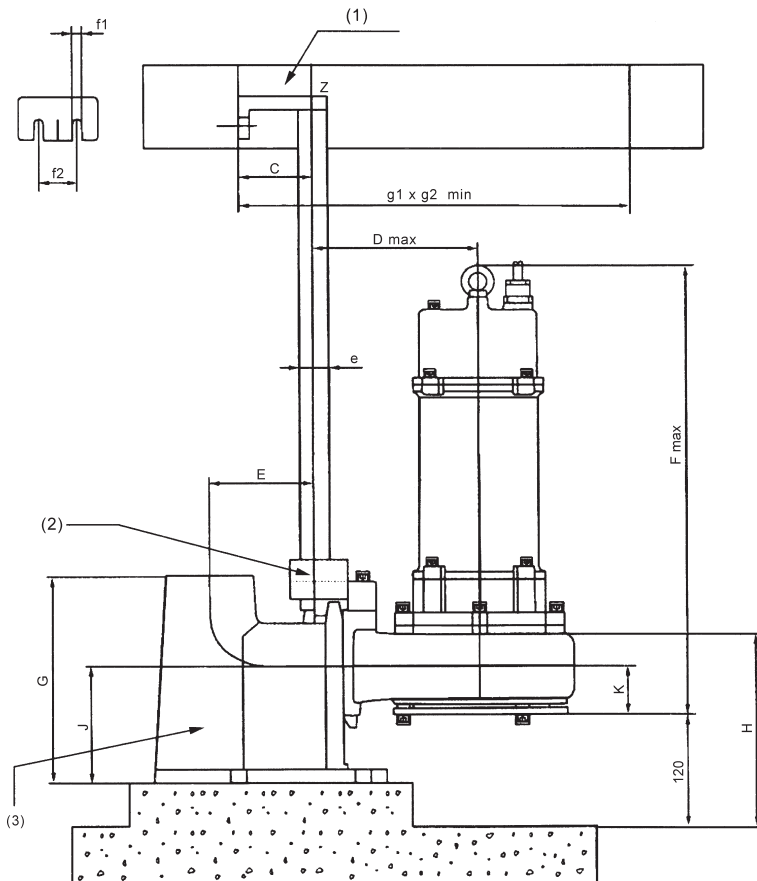

Standard Supply:

- (1) Pedestal
- (2) Bracket
- (3) Retainer

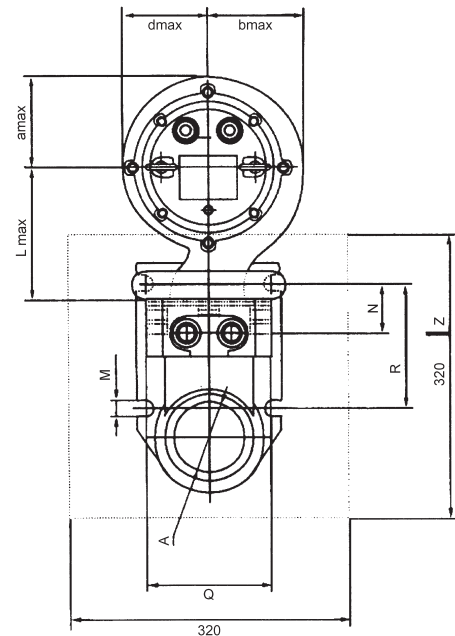

Type	A	C	D	E	F	G	H	J	L	M
50GAK	RC2"	84	170	75	515	175	185	105	145	14
80GAK	Rc3"	84	205	120	600	240	200	135	175	18
100GAK	Rc4"	105	326	238	825	385	450	205	240	18
150GAK	Rc6"	105	450	310	920	435	335	235	350	18
Type	N	Q	g ¹ xg ² (min)	R	a	b	d	k	f1/f2	e
50GAK	50	110	500x500	102	95	110	98	50	12/46	3/4"
80GAK	55	145	500x500	140	120	132	128	85	12/46	1"
100GAK	13	300	500x700	250	212	212	212	191	12/210	2"
150GAK	35	330	500x700	310	210	273	225	185	12/210	2"

CP Series



CP 75, 100, 150

50Hz 2900rpm

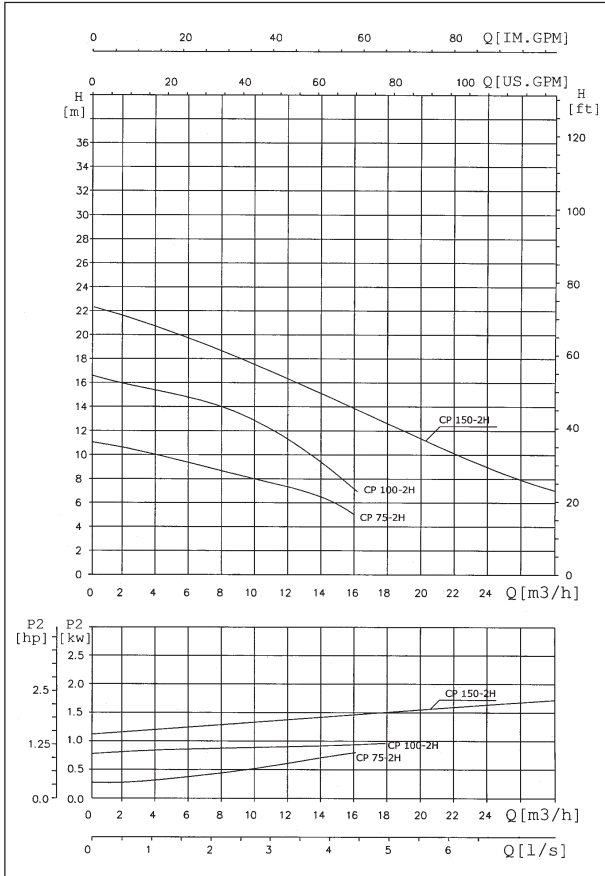

CP 220, 300, 400

50Hz 2900rpm

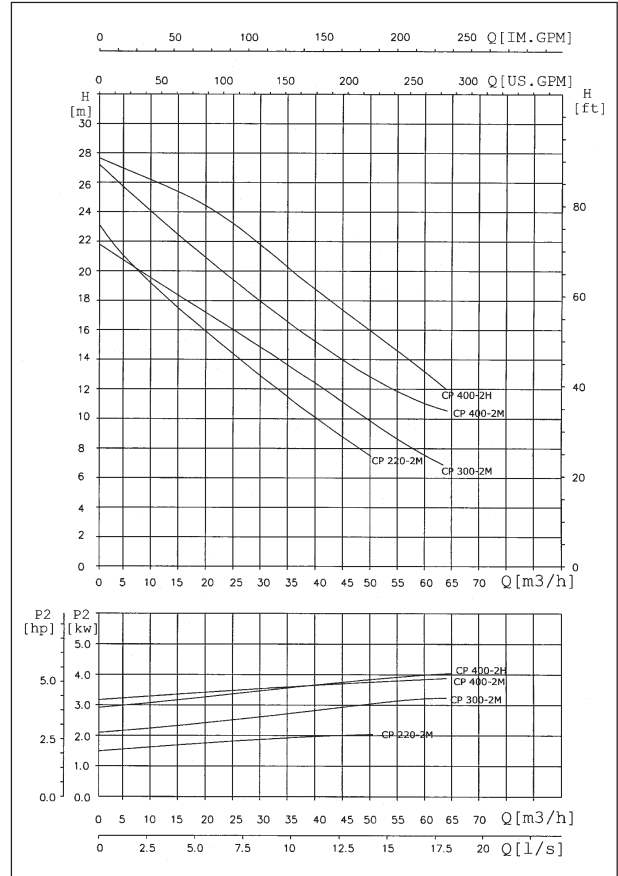

CP 100, 150, 220, 300

50Hz 2900rpm

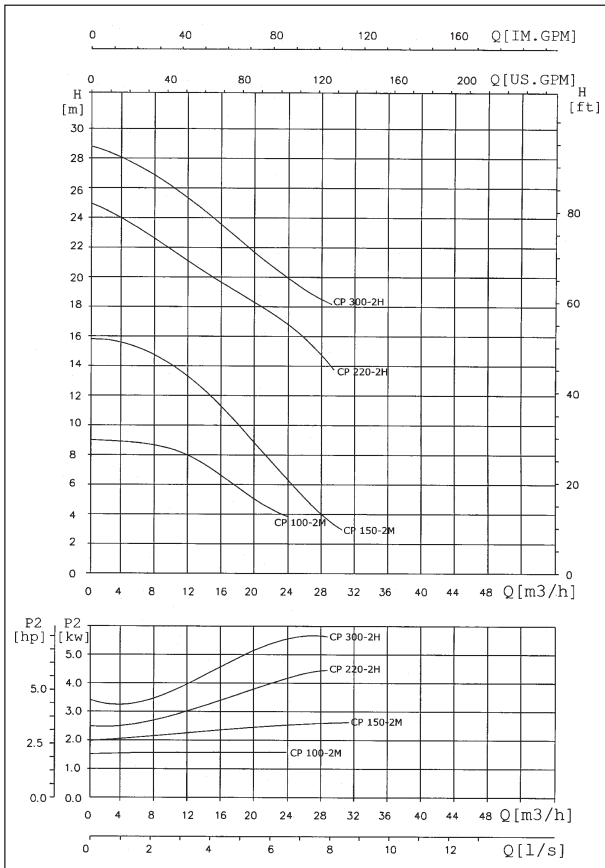

CP 550

50Hz 1450rpm

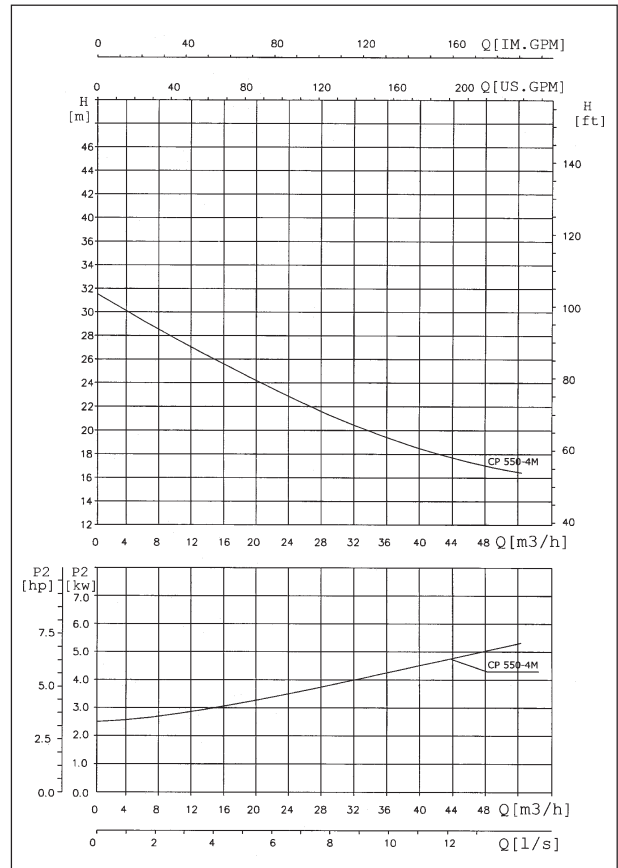

CP 750

50Hz 1450rpm

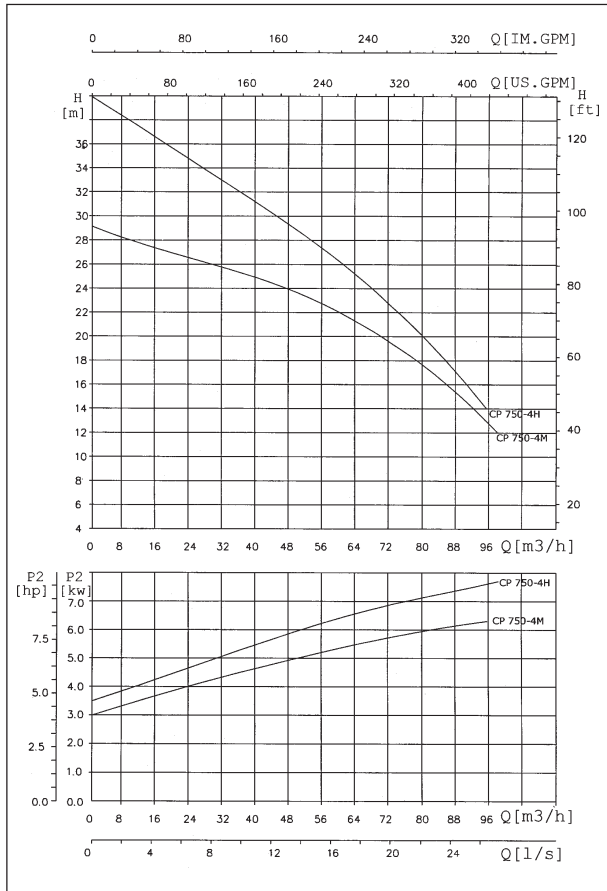

CP 550, 750

50Hz 1450rpm

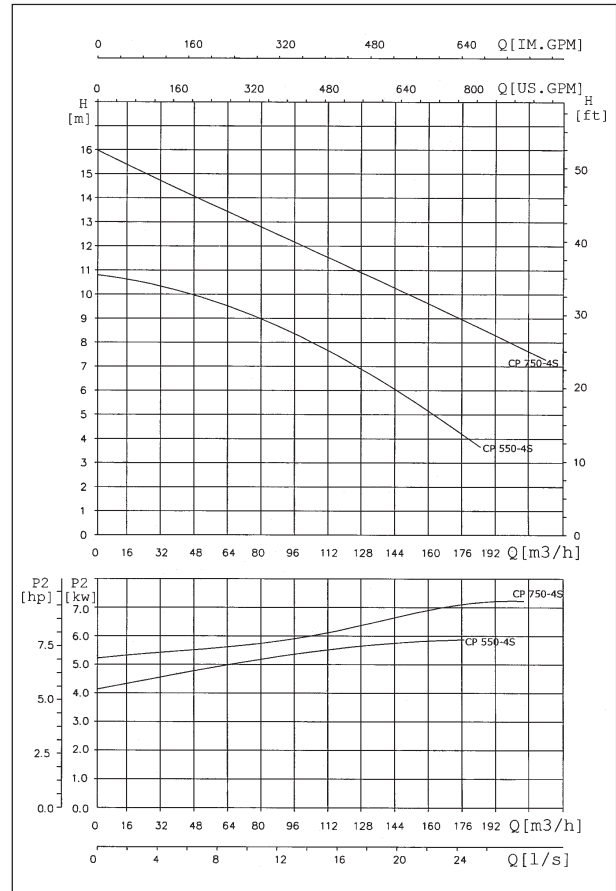

Dimensions

No	Model	A	B	C	D	E	F	G	H	J	ØM
1	CP75 – 2H(A)	90	90	125	Rc2"	175	515	300	65	65	195
	CPS75 – 2H(A)										
2	CP100 – 2H(A)	110	98	145	Rc2"	200	550	360	65	76	220
	CPS100 – 2H(A)										
3	CP150 – 2H(A)	110	98	145	Rc2"	200	585	360	65	76	220
	CPS150 – 2H(A)										
4	CP100 – 2M(A)	107	107	145	Rc3"	235	550	387	90	96	240
	CPS100 – 2M(A)										
5	CP150 – 2M(A)	107	107	145	Rc3"	235	585	387	90	96	240
	CPS150 – 2M(A)										
6	CP220 – 2M(A)	126	126	165	Rc3"	250	615	428	90	96	240
7	CP220 – 2H(A)										
8	CP300 – 2M(A)										
9	CP300 – 2H(A)										
10	CP400 – 2M(A)	132	128	175	Rc3"	285	695	445	90	96	240
11	CP400 – 2H(A)										
12	CP550 – 4M	200	155	240	Rc4"	526	915	620	210	310	450
13	CP750 – 4M										
14	CP750 – 4H										
15	CP550 – 4S	230	180	248	Rc6"	572	970	745	265	335	450
16	CP750 – 4S										

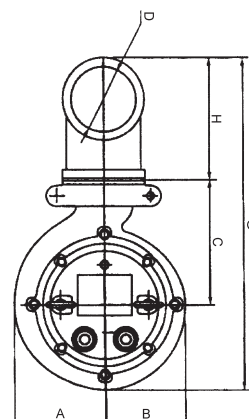
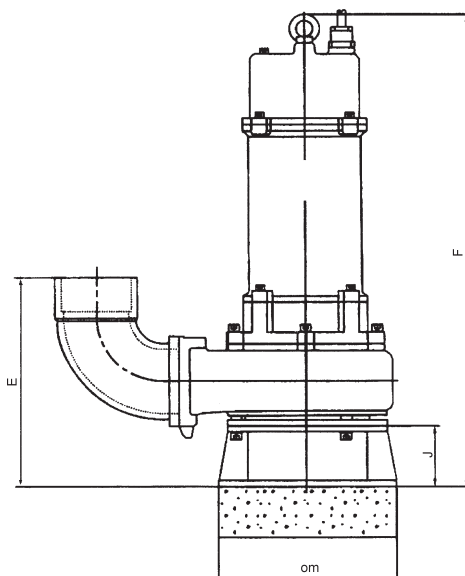

Transportable

Specification

No	Model	Capacity (m ³ /h)	Head (m)	Power (Kw)	Speed (Rpm)	Outlet (mm)	Phase	Weight (Kg)	Solids Passed (mm)		
1	CP 75-2H (A)	10	8	0.75	2900	(50GAK)	3	33	45		
	CPS 75-2H (A)						1				
2	CP 100-2H (A)	10	13	1.0			3				
	CPS 100-2H (A)						1				
3	CP 150-2H (A)	10	18	1.5			3			35	
	CPS 150-2H (A)						1				
4	CP 100-2M (A)	17	6	1.0		3	33	65			
	CPS 100-2M (A)					1					
5	CP 150-2M (A)	20	9	1.5		3	35				
	CPS 150-2M (A)					1					
6	CP 220-2M (A)	30	13	2.2		(80GAK)	3		45	75	
7	CP 220-2H (A)	15	20								
8	CP 300-2M (A)	35	14	3							
9	CP 300-2H (A)	20	22								
10	CP 400-2M (A)	40	15	4				65			
11	CP 400-2H (A)	30	21								
12	CP 550-2H	25	30	5.5				(100GAK)	3	180	80
13	CP 550-2M	30	21								
14	CP 550-2S	65	15								
15	CP 750-2H	45	30	7.5							
16	CP 750-2M	70	20								
17	CP 750-2S	80	15								
18	CP 1100-4H	45	32	11		1450	(150GAK)			200	
19	CP 1500-4H	70		15							
20	CP 550-4S	100	8	5.5	180						
21	CP 750-4S	150	10	7.5							
22	CP 1100-4M			11	200						
23	CP 1500-4M	250	13	15							

Automatic type and common type are available on request.

Description of CP Pump

Cabinet:

built-in-cabinet with an integrated circuit inside to connect with float switch, TCS & DI. It can switch on/off the pump automatically. Just connecting pump to power directly.

Motor:

Squirrel-cage motor 110V–440V, 50 or 60Hz, single/three phase, 2 pole (2800 rpm), protection type IP 68, insulation class F = 155°C, operation system SI, with TCS-Thermal-Control-System by thermal sensors in each phase of the stator to switch off the pump in the case of over-heating of the motor.

Oil Chamber:

Filling in with lubricating oil. DI system with a sensor in it to give a timely indication that an inspection is due and that leakage at the shaft seal has occurred.

Cable:

Separate, water-pressure tight encapsulated connection chamber, cable inlet with strain relief and anti-kink protection. On the end of cable, connected with an indicator. Red light for power and yellow light indicates leakage.

Bearing:

Lubricated for life maintenance-free ball bearings. SKF or FAG.

Mechanical Seal:

Double highly quality sealing unit using a tungsten carbide mechanical seal, independent of direction of rotation and resistant to temperature shock.

Impeller:

Open single channel impeller with large free solids passage. Also with a hardened cutter in the edge, strictly static and dynamic balance checked, pump operating smoothly and fibrous material can be cut in piece and passed.

Cutter

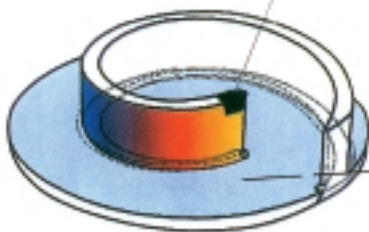

PARAGON PUMP COMPANY, LLC

18102 Courtney Breeze Drive
Tampa, Florida, 33647, USA
Tel : (813) 994-3356
Fax : (813) 994-1237

PARAGON PUMP (ASIA) PTE LTD

37 Kallang Pudding Road #08-08
Tong Lee Building Block B
Singapore 349315
Tel : (65) 6841-2818
Fax : (65) 6841-5988